

ELECTRIC SAIL-DRIVE ROTATABLE

Maximum performance

Electric Sail-Drive's superior torque curve, in respect to conventional diesel marine engines, make the electric drive system a better choice for your yacht.

The asynchronous motor is brushless and absolutely free of maintenance.

Effective 3-blade propellers make low revolutions possible, offer high thrust performance and save a lot of space.

Controllable

The single-lever offers continuous control and operates the motor in forward and reverse gear.

The highly sophisticated control works without any energy loss.

Low-noise

The low noise electric motor is almost free of vibration.

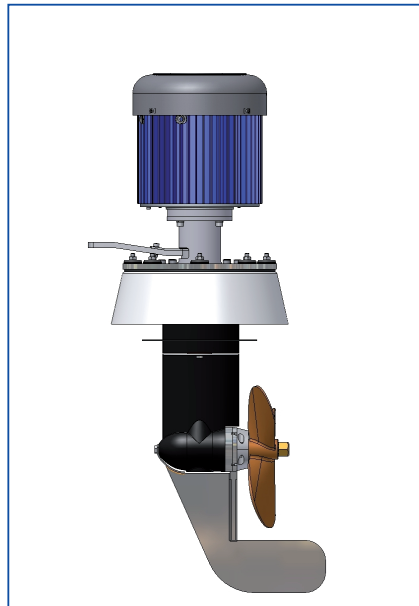

SDK-D 2,5 - 6,0 AC

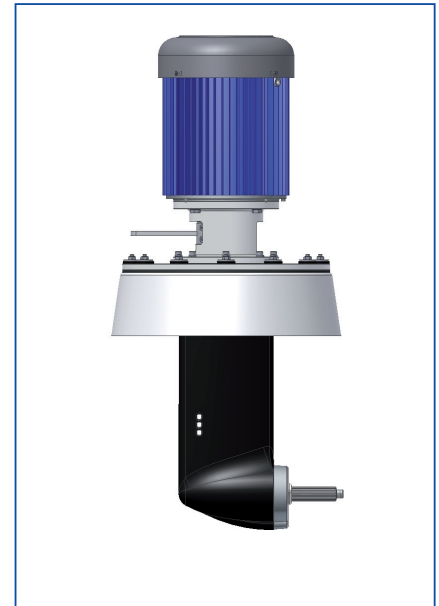

SDK-D 8,0 - 25,0 AC

Environmental friendly

Electric motors are totally emission-free. They are the future in maritime applications, since they apply to all environmental protection requirements, today and in future.

Easy to install

The Sail-Drive is supplied with a base plate for lamination onto the vessel's hull to keep installation work to a minimum.

For installation of the Sail-Drive onto an existing "Volvo" or "Yanmar" plate.

Rotatable

Our rotatable Sail-Drive is equipped with a control lever.

Therefore the Sail-Drive can be turned with a "bowden cable" 45° to each side.

This provides maximum manoeuvrability.

Type	Power consumption	Power output	Voltage	Current	Total efficiency	Weight	up to displacement	
							Sailingboot	Powerboot
SDK-D 2,5 AC	3,1 kW	2,5 kW	24 V	130 A	80 %	52 kg	-	1,0 t
SDK-D 3,5 AC	4,1 kW	3,5 kW	36 V	115 A	85 %	52 kg	-	1,4 t
SDK-D 4,3 AC	5,0 kW	4,3 kW	48 V	104 A	85 %	52 kg	-	1,7 t
SDK-D 5,0 AC	5,9 kW	5,0 kW	48 V	123 A	85 %	52 kg	-	2,0 t
SDK-D 6,0 AC	7,1 kW	6,0 kW	48 V	148 A	85 %	71 kg	-	2,4 t
SDKH-D 8,0 AC	9,4 kW	8,0 kW	48 V	196 A	85 %	83 kg	-	3,2 t
SDKH-D 10,0 AC	11,8 kW	10,0 kW	96 V	123 A	85 %	83 kg	-	4,0 t
SDKH-D 15,0 AC	17,1 kW	15,0 kW	96 V	178 A	88 %	94 kg	-	6,0 t
SDKH-D 20,0 AC	22,8 kW	20,0 kW	96 V	237 A	88 %	104 kg	-	8,0 t
SDKH-D 25,0 AC	28,4 kW	25,0 kW	96 V	296 A	88 %	104 kg	-	10,0 t

Higher performances on request

Base plate and shaft

Up to SDK 6,0 AC - small base plate and shaft diameter 25 with 1:10 cone
From SDKH 8,0 AC - big base plate and shaft diameter 25 with 1:10 cone



Krätler Elektromaschinen GmbH, Hohenemser Str. 47, A-6890 Lustenau, Austria
Phone ++43 / 55 77 / 82 534-0, Fax ++43 / 55 77 / 82 534-10
www.kraeutler.at, E-mail: kraeutler@kraeutler.at